

DHD670-E/DWU670-E

Corporate AV
Government
Higher education
Houses of worship
Large venue



Lens sold separately

Exceptional images, performance and value.

Best suited for mid- to large-sized boardrooms, breakout rooms, churches and classrooms, the Christie DHD670-E (5800 ANSI lumens/6400 center lumens) and Christie DWU670-E (6000 ANSI lumens/6500 center lumens) provide exceptional brightness and image quality. These new 1-chip DLP® models offer HD (1920x1080) or WUXGA (1920x1200) resolutions in a compact chassis, along with reliable, long-life performance – all backed by Christie's industry-leading warranties, service and support.

This dual lamp platform operates in single or dual lamp modes, and can produce higher lumen levels in a single lamp than other dual lamp projectors. The dust-sealed, filter-free design prevents dust and dirt from affecting the system – ensuring that image quality is maintained and maintenance costs are low. A full suite of optional lenses provides you with more options to meet your application needs.

Power, performance, quality, these new Christie 1-chip DLP® projectors provide extra value at no extra cost.

CHRISTIE®

		DHD670-E	DWU670-E
Image	brightness	<ul style="list-style-type: none"> High brightness color wheel (RGBCYW) <ul style="list-style-type: none"> Dual lamp: 5800 ANSI lumens (6400 center lumens) Single lamp: 3850 ANSI lumens (4250 center lumens) Optional rich color wheel (RGBCYM) <ul style="list-style-type: none"> Dual lamp: 3850 ANSI lumens (4250 center lumens) Single lamp: 2550 ANSI lumens (2800 center lumens) 	<ul style="list-style-type: none"> High brightness color wheel (RGBCYW) <ul style="list-style-type: none"> Dual lamp: 6000 ANSI lumens (6500 center lumens) Single lamp: 4000 ANSI lumens (4400 center lumens) Optional rich color wheel (RBCYM) <ul style="list-style-type: none"> Dual lamp: 4000 ANSI lumens (4400 center lumens) Single lamp: 2700 ANSI lumens (3000 center lumens)
	contrast	• 5000:1 (full on/off), 150:1 minimum ANSI	
Display technology	type	• 1-chip 0.65" DMD	• 1-chip 0.67" DMD
	native resolution	• HD (1920 x 1080) 16:9	• WUXGA (1920 x 1200) 16:10
Input	signals	<ul style="list-style-type: none"> HDTV formats VGA through to WUXGA (1920 x 1200) Horizontal and vertical scaling while maintaining aspect ratio, all inputs 	
	pixel clock	• 162 MHz	
	scan rates	• Horizontal: 15 kHz to 100 kHz • Vertical: 24 Hz to 85 Hz	
Inputs/ outputs, control and networking	inputs	<ul style="list-style-type: none"> Built-in backlit keypad • One RS232 port • On-board connectivity (RJ45) • One USB port (Type B) – for SW upgrades • One composite video • One S-video • Two HDMI (version 1.3v) One YpPr In (Component Video) • RGBHV via 5 BNC • Two VESA inputs for RGBHV Accepts all current HDTV/DTV formats • One VESA output loop thru to monitor 	
	lens mount	<ul style="list-style-type: none"> Motorized horizontal and vertical lens offset • Motorized zoom and focus adjustment User replaceable lenses 	
Lamp	type	• Dual 330W P-VIP® Osram	
	life	<ul style="list-style-type: none"> 1500hrs max power (3000hrs lamp sequential mode) 2000hrs eco mode (4000hrs lamp sequential mode) 	
Installation	• 360 degree installation for horizontal, ceiling and vertical positions		
Illumination	• Dust sealed, 1-chip DMD light engine • Motorized iris • Built-in shutter		
Optional lenses	fixed	• 0.8:1	
	zoom	• 1.2-1.5:1 • 1.5-2.0:1 • 2.0-4.0:1 • 4.0-7.0:1	
	offsets	<ul style="list-style-type: none"> +67% vertical (HD – 720 pixels)/ -22% vertical (HD – 240 pixels) ±10% horizontal (±192pixels) 	<ul style="list-style-type: none"> +60% vertical (WU – 720 pixels)/ -20% vertical (WU – 240 pixels) ±10% horizontal (±192pixels)
Accessories	standard	<ul style="list-style-type: none"> High brightness color wheel (RGBCYW) IR remote (w/batteries) • Locking HDMI to DVI adapter 	
	optional	• Rich color wheel (RGBCMY) • Ceiling mount	
Enhanced feature sets	<ul style="list-style-type: none"> No filters required • Dynamic aperture • PiP/PbP • Lamp auto relay feature User-replaceable color wheels • Optimized single lamp operation for maximum brightness • User-accessible lamp change from top of projector • Single lamp module usable in any lamp position • Energy saving standby mode • Menus in nine languages High altitude mode • 360 degree operation • Ceiling mount adjustments 		
	Power requirements	operating voltage	• 100 VAC to 240 VAC @ 50/60 Hz
	operating current	• 10.5A @ 100VAC	
	power consumption	• 1050W maximum • 835W eco mode	
	dissipation	• Standby eco mode power <0.2W	
		• 3586 BTU/hr max • 2850 BTU/hr eco mode	
Dimensions	size	• (LxWxH): 20.9 x 18.0 x 8.3" (532 x 456 x 210mm) excluding feet	
	shipping size	• (LxWxH): 23.3 x 38.0 x 15.4" (591 x 965 x 390mm)	
	weight	• 43lbs (19.5kg) – Shipping weight: 58lbs (26.3kg)	
Operating environment	• Temperature: 40-95°F (5-35°C) • Humidity: 5-80% non-condensing		
Regulatory approvals	<ul style="list-style-type: none"> This product conforms to the following regulations related to product safety, environmental requirements and electromagnetic compatibility (EMC): FCC Part 15, Subpart B Class A • EN55024/CISPR24 Class A • UL 60950-1 CAN/CSA-C22.2 No 60950-1 • IEC 60950-1 • 2002/95/EC RoHS • 2002/96/EC (WEEE) 		
Limited warranty	<ul style="list-style-type: none"> 3 years parts and labor (including light engine) Contact an authorized Christie representative for full details of our limited warranty 		

¹In dynamic contrast mode. ²No offset

³In this mode, network functions and serial command functions not operable unless projector is turned on.



▲ When greater color accuracy is required, an optional rich color wheel gives you the ability to change the standard high brightness color wheel.



▲ Full suite of optional lenses provides installation flexibility.

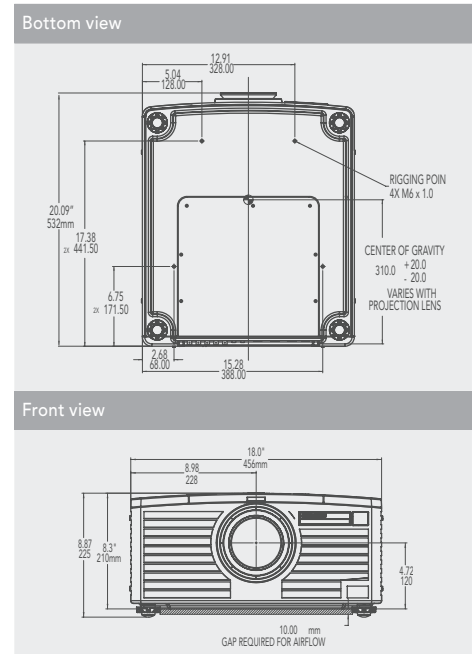

Corporate offices

Christie Digital Systems USA, Inc
USA – Cypress
ph: 714 236 8610

Christie Digital Systems Canada Inc.
Canada – Kitchener
ph: 519 744 8005

Worldwide offices

United Kingdom
ph: +44 (0) 118 977 8000

Germany
ph: +49 2161 664540

France
ph: +33 (0) 1 41 21 44 04

Eastern Europe and
Russian Federation
ph: +36 (0) 1 47 48 100

United Arab Emirates
ph: +971 (0) 4 299 7575

India
ph: (080) 41468941 – 48

Singapore
ph: +65 6877 8737

China (Shanghai)
ph: +86 21 6278 7708

China (Beijing)
ph: +86 10 6561 0240

Japan (Tokyo)
ph: 81 3 3599 7481

Korea (Seoul)
ph: +82 2 702 1601

Independent sales consultant offices

Spain
ph: +34 91 633 9990

Italy
ph: +39 (0) 2 9902 1161

South Africa
ph: +27 (0) 317 671 347

3 YEAR WARRANTY

CHRISTIE LCD,
1-CHIP AND 3-CHIP DLP®

ISO 9001



ISO 14001



For the most current specification information, please visit www.christiedigital.com

Copyright 2010 Christie Digital Systems USA, Inc. All rights reserved. All brand names and product names are trademarks, registered trademarks or tradenames of their respective holders. Canadian manufacturing facility is ISO 9001 and 14001 certified. Performance specifications are typical. Due to constant research, specifications are subject to change without notice. Printed in Canada on recycled paper. 2788 Oct 10

CHRISTIE®